

# NXWBS1

## WALL MOUNT BRACKET



### DESCRIPTION

Heavy duty bracket with joint, made of AISI 316L thick gauge stainless steel. The rotation of the joint along the vertical and horizontal axes allows a wide range of positions. It is particularly suitable for stainless steel weather-proof housings. Can be combined with NXCOL and NXCW pole and corner mount adapters.

### TECHNICAL DATA

#### MECHANICAL

Bracket for NTC, NXM36, NXM, NTM, NXW, NTW  
 Bracket for MVX, MVXT, MVXHD  
 Suitable for: NXCOL, NXCW  
 Made of AISI 316L electropolished stainless steel  
 Load rating: 45kg (99lb)  
 Dimensions: 371x186mm (14.6x7.3in)  
 Unit weight: 2.5kg (5.5lb)

### PART NUMBER

NXWBS1 AISI 316L stainless steel wall bracket with joint

### PACKAGE

Model Number	Weight	Dimensions (WxHxL)	Master carton
NXWBS1	2.8kg (6.2lb)	16x18.5x46cm (6.3x7.3x18.1in)	8

### TECHNICAL DRAWINGS

The indicated measurements are expressed in millimetres.

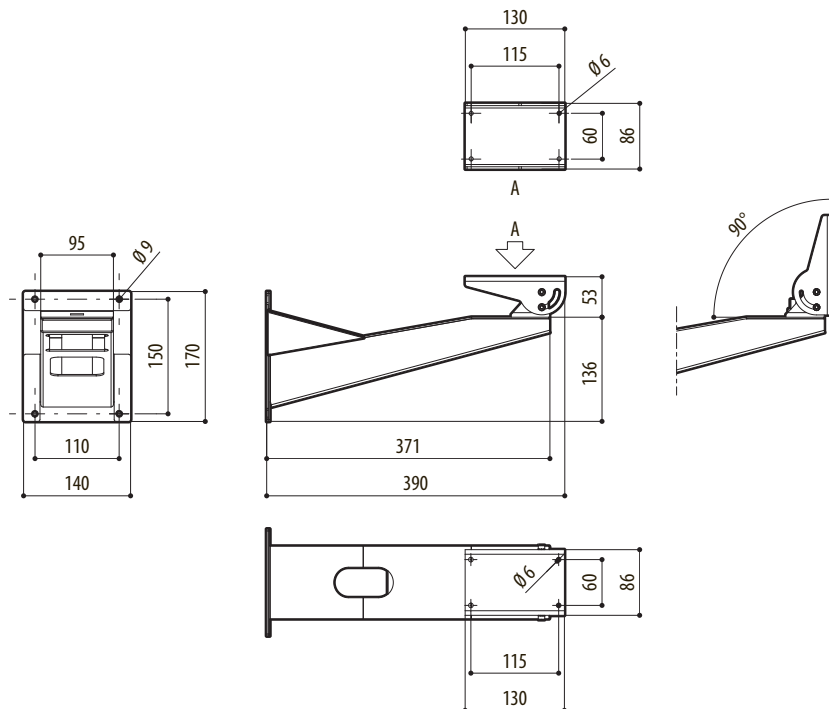

NXWBS1