

MAXIMUS MBA

EXPLOSION-PROOF COMMUNICATION BOX IN ALUMINIUM



MAXIMUS MBA

MAXIMUS MBA

DESCRIPTION

MAXIMUS MBA is much more than just a simple explosion-proof junction box. In fact it is defined as a communication box equipped with everything needed to connect one or more IP or analog cameras.

MAXIMUS MBA has been designed to integrate and work exclusively with the MAXIMUS range of Videotec products.

MAXIMUS MBA provides a local, low-voltage power supply. It also allows a Fast Ethernet connection, thanks to an integrated Ethernet switch equipped with 3 RJ45 ports and an SFP port for fibre optic connection. The type of SFP module can be chosen according to the installation requirements. The internal spaces are designed to make access to cables easier, and to increase user-friendliness when it comes to connection procedures. The internal board also offers the bypass for analog video signals and for all the inputs and outputs which are present in the Videotec MAXIMUS products.

MAXIMUS MBA has been designed to connect a PTZ camera and its washing kit, or in alternative two fixed cameras and their washing kits.

MAXIMUS MBA is built in marine grade aluminium protected by epoxy paint to offer maximum resistance in corrosive environments such as industrial or marine. MAXIMUS MBA is the complete and competitive solution for professional installation of the Videotec MAXIMUS range of explosion-proof products.

CERTIFICATIONS



Other certifications pending.

All updates on Certifications and Markings at www.videotec.com

MAIN FEATURES

Certifications for use in Zones 1 and 2, IICT5 or T6 Group (Gas) and in Zones 21 and 22, IICT100°C or T85°C Group (Dust)

Copper-free marine grade aluminium construction, RAL 9006 external epoxy paint

Designed to work exclusively with Videotec products and accessories

Plenty of space for cables and connections

Built-in Ethernet switch with 4 channels:

3 RJ45 ports, Fast Ethernet (10BASE-T/100BASE-T)

1 SFP port, Fast Ethernet (100BASE-FX), for fibre optic connection

2 bypass for analog video signals with BNC connectors

2 bypass for I/O signals with multi-pin connectors

Input voltages available: 230Vac, 120Vac, 24Vac

Extended/Industrial range electronics

Operating temperature: from -40°C (-40°F) up to +70°C (158°F)

IP66

TECHNICAL DATA

MECHANICAL

Copper-free marine grade aluminum construction
RAL 9006 epoxy exterior painting
Fastening holes: 4 x Ø13mm (0.5in)
Cable gland holes: 4 x 3/4" NPT + 2 x 1/2" NPT
External dimensions (WxHxL): 305x228x340mm (12x9x13.5in)
Unit weight: 16.3kg (36lb)

ELECTRICAL

MBA works with all MAXIMUS products in 24Vac.

Maximum power output: 120W

Input voltages available:

- 230Vac, 50/60Hz
- 24Vac, 50/60Hz
- 120Vac, 50/60Hz

Possible system configurations:

- up to 1 PTZ + 1 wash system
- up to 2 Cameras + 2 wash systems

NETWORK

4 channels unmanaged ethernet switch:

- 3 RJ45 ports
 - Ethernet connection: 10BASE-T/100BASE-T
- 1 SFP port (SMALL FORM FACTOR PLUGGABLE)
 - Ethernet connection: 100BASE-FX
 - Supply voltage: 3.3V
 - Standard: compliant MSA

The SFP module (not supplied by Videotec) must meet the following requirements:

- Laser: Class 1, complies with EN60825-1
- UL/IEC 60950-1 or 62368-1 Certification

ANALOGUE VIDEO

2 bypass for analog video signals with BNC connectors

I/O INTERFACE

2 bypass for I / O signals with multi-pin connectors

ENVIRONMENT

For indoors and outdoors installation

Installation temperature: from -60°C (-76°F) up to +80°C (+176°F) (T5) or +60°C (140°F) (T6)

Operating temperature: from -40°C (-40°F) up to +70°C (158°F)

Relative humidity: from 5% up to 95%

CERTIFICATIONS

Electrical safety (CE): EN60950-1, IEC60950-1, EN62368-1, IEC62368-1

Electromagnetic compatibility (CE): EN50130-4, EN55032 (Class B), EN61000-6-4

Electromagnetic compatibility (North America): FCC part 15 (Class B), ICES-003 (Class B)

IP protection degree (EN60529): IP66

NDAA-compliant

CERTIFICATIONS - EXPLOSION-PROOF APPLICATIONS

ATEX (EN 60079-0+A11, EN 60079-1, EN 60079-31)

IECEX (IEC 60079-0 Ed.6, IEC 60079-1 Ed.6, IEC 60079-31 Ed.2)

EAC Ex (TR CU 012/2011)

For further details on certifications and markings, consult the relevant table.

ACCESSORIES

OCTEXBA3/4P	Barrier cable gland in nickel-plated brass EX 3/4" NPT, armoured cable IECEX-ATEX-EAC Ex
OCTEXBA1/2P	Barrier cable gland in nickel-plated brass EX 1/2" NPT, armoured cable IECEX-ATEX-EAC Ex
OCTEXB3/4P	Barrier cable gland in nickel-plated brass EX 3/4" NPT, unarmoured cable IECEX-ATEX-EAC Ex
OCTEXB1/2P	Barrier cable gland in nickel-plated brass EX 1/2" NPT, unarmoured cable IECEX-ATEX-EAC Ex
OEXPLUG3/4P	Plug EX 3/4" NPT IECEX-ATEX-EAC Ex
OEXPLUG1/2P	Plug EX 1/2" NPT IECEX-ATEX-EAC Ex
OCTEX1/2-3/4P	Cable glands reduction in nickel-plated brass Ex 3/4" - 1/2" NPT IECEX-ATEX-EAC Ex

For further details about cable glands part numbers, please refer to the relevant table.

RELATED PRODUCTS*

MAXIMUS MHX	Ex-proof stainless steel housing
MAXIMUS MHXT	Ex-proof stainless steel housing for thermal cameras
MAXIMUS MMX	Ex-proof FULL HD camera in a compact design
MAXIMUS MPX	Ex-proof PTZ Day/Night camera
MAXIMUS MPXT	Dual vision PTZ with Day/Night and thermal cameras
MAXIMUS MPXHD	Explosion-proof Full HD PTZ camera
MAXIMUS MPX DELUX	Explosion-proof Full HD PTZ camera
MAXIMUS MVX	Ex-proof Day/Night camera
MAXIMUS MVXT	Ex-proof thermal camera
MAXIMUS MVXHD	Ex-proof FULL HD camera
MAXIMUS MVX DELUX	Ex-proof FULL HD camera
WASEX	Washer pump with ex-proof solenoid valve

*MAXIMUS MBA can only be installed with the products of the MAXIMUS line.

PACKAGE

Model Number	Weight	Dimensions (WxHxL)	Master carton
MBA155A	20kg (44lb)	66x33x57cm (26x13x22in)	-

CABLE GLANDS AND ACCESSORIES 1/2" NPT						
Type	Certification	Operating temperature	Cable	Model Number	Diameter of the external cable	Under armor cable diameter
Barrier cable gland	IECEX/ATEX/EAC Ex	-60°C (-76°F) / +135°C (275°F)	Unarmoured cable	OCTEXB1/2P	12.5 - 14.0mm (0.5-0.55in)	–
			Armoured cable	OCTEXBA1/2P	15.5 - 21.1mm (0.61-0.83in)	–
Plug EX 1/2"NPT	IECEX/ATEX/EAC Ex	-100°C (-148°F) / +400°C (752°F)	–	OEXPLUG1/2P	–	–

CABLE GLANDS AND ACCESSORIES 3/4" NPT						
Type	Certification	Operating temperature	Cable	Model Number	Diameter of the external cable	Under armor cable diameter
Barrier cable gland	IECEX/ATEX/EAC Ex	-60°C (-76°F) / +135°C (275°F)	Unarmoured cable	OCTEXB3/4P	17.8 - 20.0mm (0.70-0.79in)	–
			Armoured cable	OCTEXBA3/4P	16.8 - 23.9mm (0.66-0.94in)	–
Conduit sealing fitting	IECEX-ATEX- c CSA us - EAC Ex	-60°C / +80°C (-76°F / +176°F)	–	OCTEXP3/4C	–	–

MAXIMUS MBA - CERTIFICATIONS AND MARKINGS		
Certification	Marking	Ambient temperature
ATEX	Ⓜ II 2 G Ex d IIC T5 Gb Ⓜ II 2 D Ex tb IIIC T100°C Db IP66	-60°C ≤ Ta ≤ +80°C
	Ⓜ II 2 G Ex d IIC T6 Gb Ⓜ II 2 D Ex tb IIIC T85°C Db IP66	-60°C ≤ Ta ≤ +60°C
IECEX	Ex d IIC T5 Gb Ex tb IIIC T100°C Db IP66	-60°C ≤ Ta ≤ +80°C
	Ex d IIC T6 Gb Ex tb IIIC T85°C Db IP66	-60°C ≤ Ta ≤ +60°C
EAC Ex	1Ex d IIC T5 Gb X Ex tb IIIC T100°C Db X	-60°C ≤ Ta ≤ +80°C
	1Ex d IIC T6 Gb X Ex tb IIIC T85°C Db X	-60°C ≤ Ta ≤ +60°C

MAXIMUS MBA - CONFIGURATION OPTIONS			
	Input voltage		Temperature class
MBA	1 230Vac	S	5 T5 -60°C/+80°C
	2 24Vac		6 T6 -60°C/+60°C
	3 120Vac		

TECHNICAL DRAWINGS

The indicated measurements are expressed in millimetres.

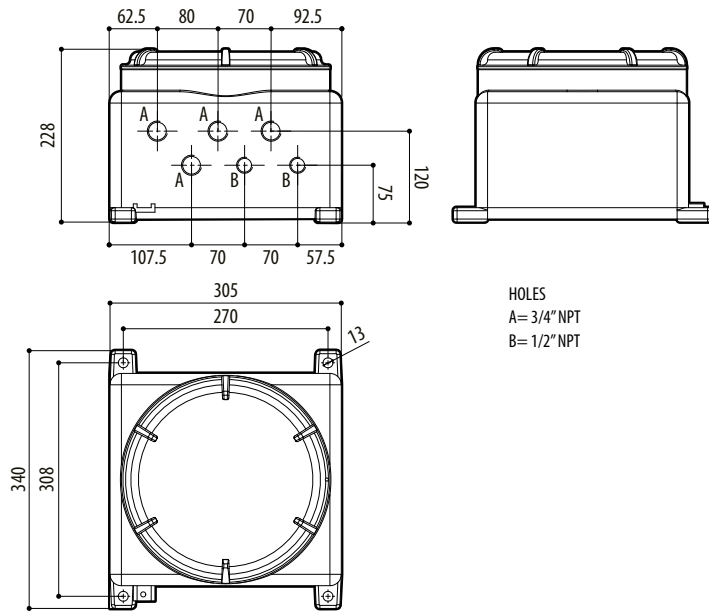

MAXIMUS MBA